

KLOVER MiK 16

Assembly & Care

Assembly Instructions:

Step 1 - Place the parabolic dish on a soft, clean surface with the open end facing downward.

Step 2 - Install the rear (horizontal) handle "T" bar on the bottom connector with the remaining connectors pointing outward and the tapped hole facing away from the center of the collector dish.

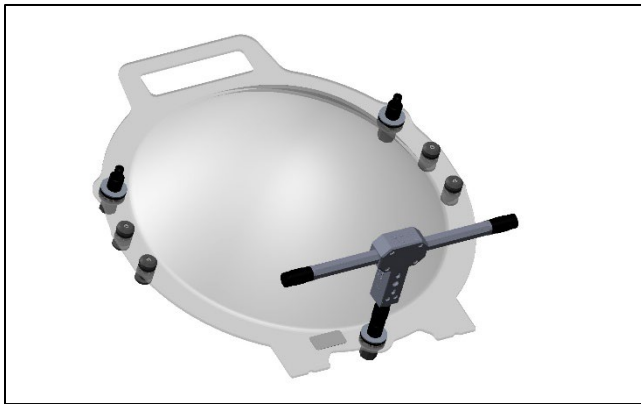

Step 3 - Install the right-hand and left-hand handles by snapping them onto the horizontal "T" bar and the appropriate dish connector. (The connectors at the bottom of the handle will point toward the center of the collector dish.) You may have to rotate the connectors on the dish slightly to get the handles to snap into place.

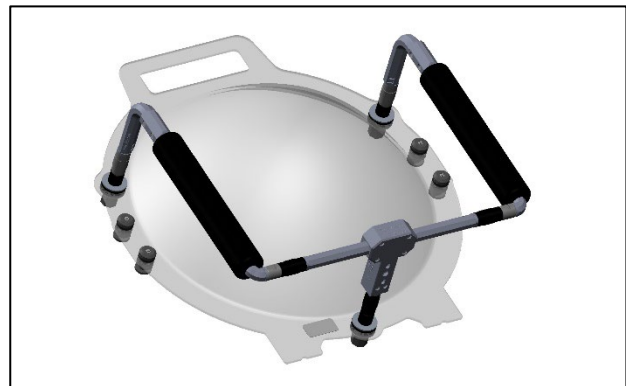
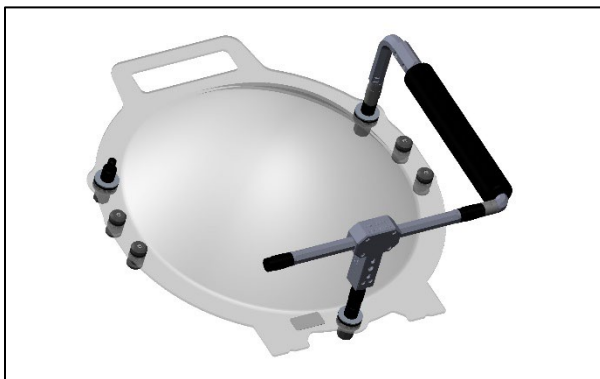

Step 4 – Install the microphone into the mic yoke and snug the thumb screw against the mic. If you are using a lapel microphone, thread the microphone through the adapter tube, snap the microphone into

the mic clip, and then slide the mic clip into the tapered end of the adapter tube. (We suggest wrapping the microphone cable with the foam and sliding the foam into the opposite end of the adapter tube.)

Step 5 - Position the mic at the Focus point. To accomplish this, locate the center of the microphone's pickup pattern 1-1/8-inch behind the rear face of the mic yoke for "standard" dishes and 1-15/16-inch behind the rear face of the mic yoke for our "deep" dishes. The width of the foot at the bottom of the collector dish will be the correct focus distance for your dish. In addition, a focus guide is built into the mic yoke end plate. The width of the "Focus Guide" protrusions will be the correct focus distance for your dish. You can use either feature to set the position of the microphone. (We typically assume the center of the pickup pattern is at the end of the microphone, without a windscreen installed.)

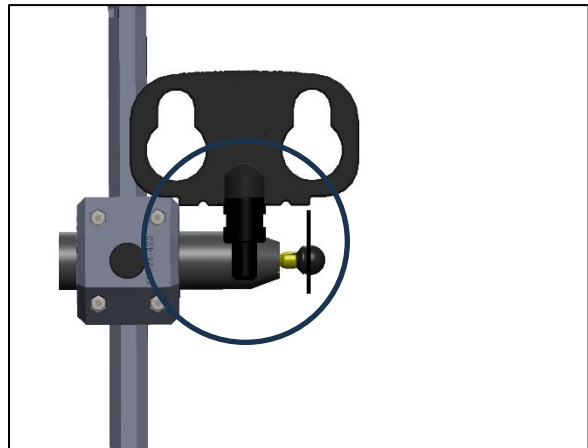
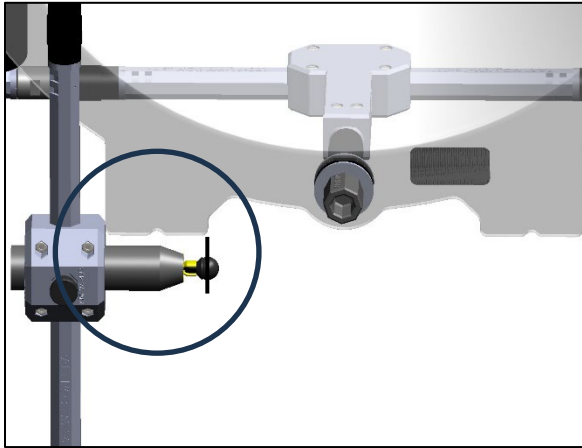

Step 6 - Install the mic yoke with the thumb screw on the bottom and the targeting site features on top. Begin by removing one end plate from the microphone yoke. Slide the end plate, which is still attached to the mic yoke, onto one set of the dish's locator pins. Place the loose end plate onto open locator pins on the opposite side of the dish and snap it into the end of the mic yoke.

Moving the microphone in or out from the exact focus point can slightly alter the frequency response of the KLOVER MiK. Feel free to experiment with the mic location.

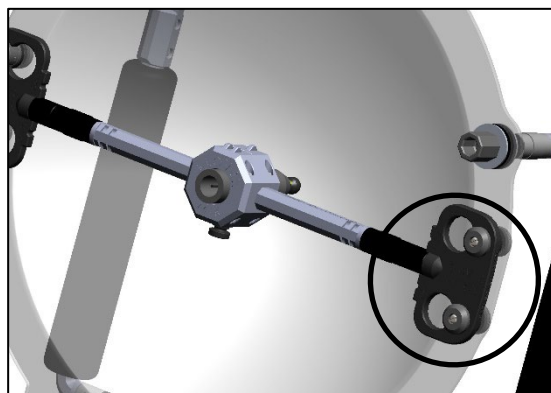
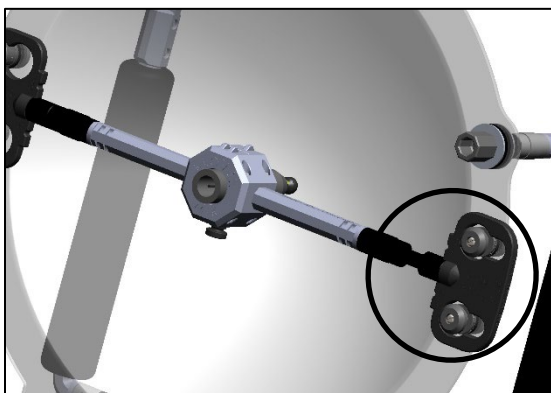

You **MUST** see the printing on the end plates and the mic yoke hub from the front of the dish, AND the arrows on the end plate must point toward the targeting site features on the mic yoke hub. If either is incorrect, the microphone will tilt at a noticeable angle.

For video demonstrations of the assembly process, please visit our support page at kloverproducts.com/support.

Cleaning Instructions:

- ONLY use an ammonia-free cleaning product, such as "Sparkle," to clean the parabolic dish.

Registration:

- Please register your product using the Registration form at klovermik.com/registration so we can inform you of any updates or other important news.

Troubleshooting:

If you are having problems getting audio from your KLOVER MiK 16:

- 1) Verify that your microphone is facing toward the inside of the dish and located at the focus point.
- 2) Verify that your gain is adjusted correctly and that you are recording/monitoring the proper channel(s).
- 3) Verify your microphone is receiving power.
 - a) If you purchased a kit with an XLR microphone (large 3-pin connector), ensure your camera or recording device provides phantom power. There is almost always a physical switch or setting to turn this power ON or OFF.
 - b) If you purchased a kit with a 3.5mm microphone (connector that looks similar to a headphone's), ensure your camera or recording device provides bias voltage (plug-in power). Many recorders, such as the Zoom H series, have a setting to turn this power ON or OFF.
 - c) Please check your device's manual to ensure it can provide this power. If not, please get in touch with us directly to help you find the best way to proceed.

If you are still dissatisfied with the audio you capture, please email us at help@KloverProducts.com or call us at (608) 371-5660.



US Patent #9014402

Klover Products Inc.
5807 W Fenrick Rd
Janesville, WI 53548
(608) 371-5660 - (888) 299-9009
www.KloverProducts.com
support@KloverProducts.com

**The inside surface of
the dish is critical to
this product's
performance.**

DO NOT

**place or store
anything inside the
dish, or clean the dish
with an ammonia-
based cleaner.**